

Stator for Flanged Torque Sensor 8675

non-contact

MODEL **8675-STATOR** **NEW**



Highlights

- Contactless data transmission
- Configurable alarm signal
- USB measuring function
- Easy mounting and alignment to the rotor
- Analog output: ± 10 V
- Frequency output (RS 422)
- Configurable via USB



Rotor with stator



Contactless data transmission

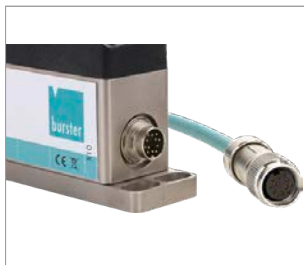

Connector plug



USB connection

Product description

The stator (receiver) model 8675-STATOR is required for the function of the flange torque sensor model 8675.

The transmission of measurement data is contactless and therefore completely maintenance-free. The optical data transmission (infrared) reduces EMC radiation to a minimum. Typical industrial conditions such as oil mist, brake dust etc. are also no problem for optical transmission and the measurement data is transmitted reliably.

The rotor can be changed without reconfiguration, the characteristic values are transmitted automatically and the stator is adjusted to the rotor.

The output signal can be switched from ± 10 volts to 60 kHz ± 20 kHz (RS422) via USB. Measurement data acquisition via USB is also possible with the DigiVision software.

In addition to the output signal, an alarm signal is also available. This can be freely programmed, e.g. signal at 110 % of the measuring range.

Technical data

8675		-	Stator				
Electrical values							
Supply voltage			12 ... 26 V DC				
DC power consumption			< 12 W				
Output signals (configurable)			Frequency output (RS-422): 60±20 kHz Analog output: 0 - 5 V, 0 - 10 V, ±5 V, ±10 V				
Ambient conditions							
Rated temperature range rotor/stator			0 °C ... +50 °C				
Operating temperature range rotor/stator			-10 °C ... +50 °C				
Installation							
Radial distance rotor/stator	[mm]		3 (+1/-2)				
Axial distance rotor/stator	[mm]		7 (±1)				
Miscellaneous							
Weight	[kg]		1,0				
Protection class			IP54				

Dimensional drawing

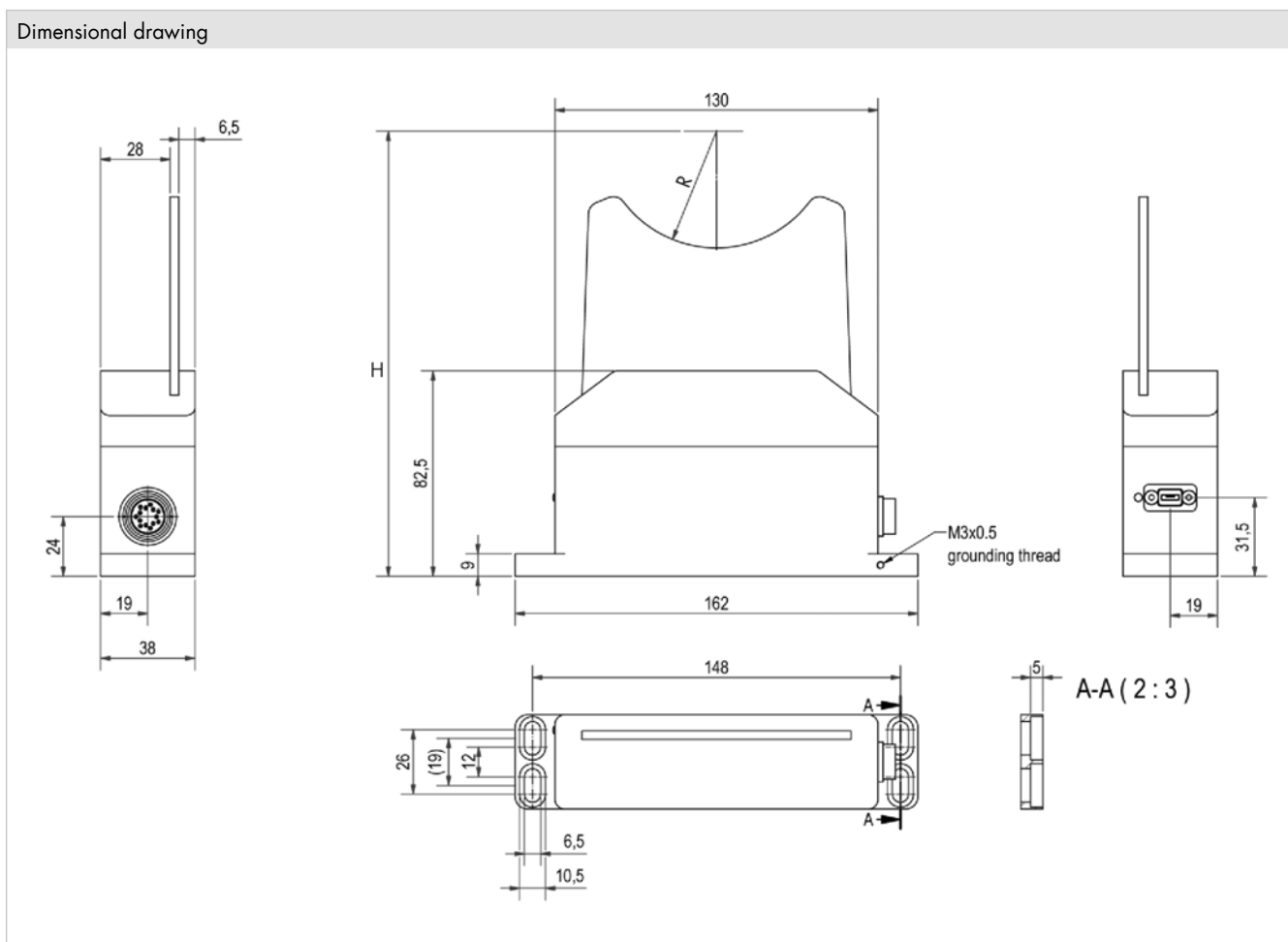

8675		-	Stator						
Measuring range from 0 ...	[N·m]		100	200	500	1000	2000	3000	5000
Geometry									
H	[mm]		139		149.5		164.5		179
R (Center Rotor)	[mm]		30		36		37		47

Accessories

Order code	
9900-V680	Mating connector for X10 (included with device)
9900-K501	Connecting cable for X10: one end open, length 5 meters

Calibration

Test and calibration log	
Is supplied with the sensor	With details of the zero point, full-scale output and shunt calibration.
Standard factory calibration certificate for torque sensors or measurement chains (WKS)	
Optionally available	Calibration of the clockwise and/or anticlockwise torque in steps of 20 % of the measuring range, rising and falling.
Special factory calibration certificate for torque sensors or measurement chains (WKS)	
On request	We are happy to calibrate sensors and measurement chains to the customer's specification.
Calibration certificate with accreditation symbol for 8675 torque sensor	
Optionally available	Calibration is based on the accreditation of calibration laboratory D-K-15141-01-00, for the scope of parameters listed in the annex to the accreditation certificate. Traceability to national standards and wide international recognition is therefore assured (DAkkS is a signatory to the EA, ILAC and IAF Multilateral Recognition Arrangements). Calibration services not covered by the D-K-15141 calibration laboratory may be carried out by an external laboratory that has DAkkS accreditation for the required scope of services.

Order code

depending on the sensor used model 8675

8	6	7	5	-	X	X	X	X	-	V	0	0	0		0
														⋮	
■ Measuring range rotor -5100 and -5200 (100 and 200 N·m)														1	
■ Measuring range rotor -5500 and -6001 (500 and 1000 N·m)														2	
■ Measuring range rotor -6002 and -6003 (2000 and 3000 N·m)														3	
■ Measuring range rotor -6005 (5000 N·m)														4	